

# BORNEO

S Y S T E M S



**EXTERNAL VENETIAN BLINDS SYSTEM**

# BORNEO

---

S Y S T E M S

## EXTERNAL VENETIAN BLINDS SYSTEM



Protection from sunlight



Protection of privacy



Saving energy



We from BORNEO Systems offer you the ideal solution for external blinds or raffstores in order to make the best of the natural daylight.

The individual adjustable slats allow an up to 180 degree regulation in order to control the light intensity as well as protect your privacy.

Our BORNEO Systems venetian blinds allow for an energy-saving cooling, especially on hot summer days. The dimming of the rooms saves money and energy.

BORNEO Systems is most suitable for:

- single-family homes
- multi-family homes
- town house
- appartements
- offices
- industrial buildings
- production halls
- etc.

BORNEO Systems offers two varieties of venetian blinds in accordance with the surface of your facade:

1. aluminium side channels
2. PVC-covered stainless steel wire

BORNEO Systems creates a feel-good atmosphere in your own living and working spaces!

## EXTERNAL VENETIAN BLINDS SYSTEM





EXTERNAL VENETIAN BLINDS SYSTEM





## EXTERNAL VENETIAN BLINDS SYSTEM

# BORNEO SW

Borneo SW is an external blinds system assembled with two PVC-covered stainless steel wires.

The custom-made external construction enables the possibility to properly install the blind slats without the support surface.

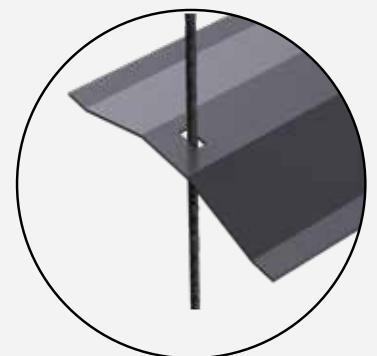
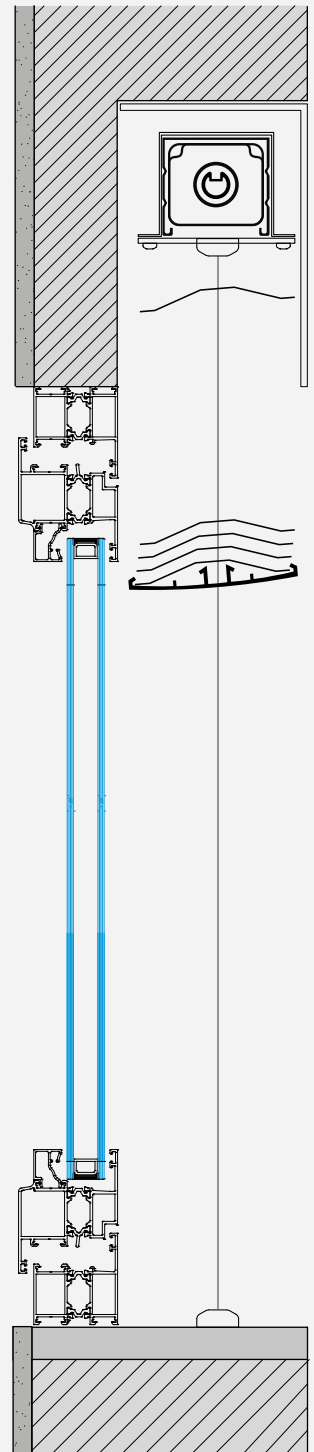
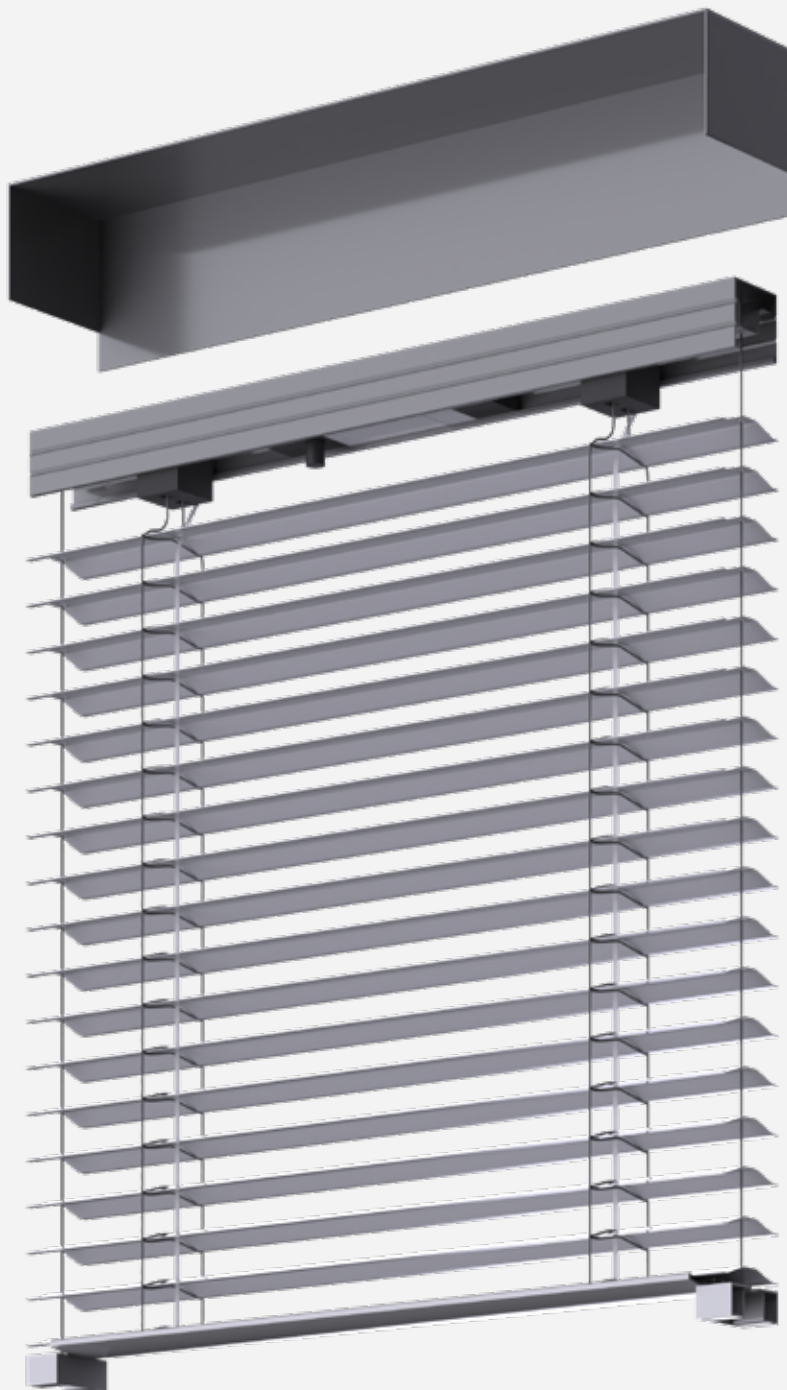



# Ceiling

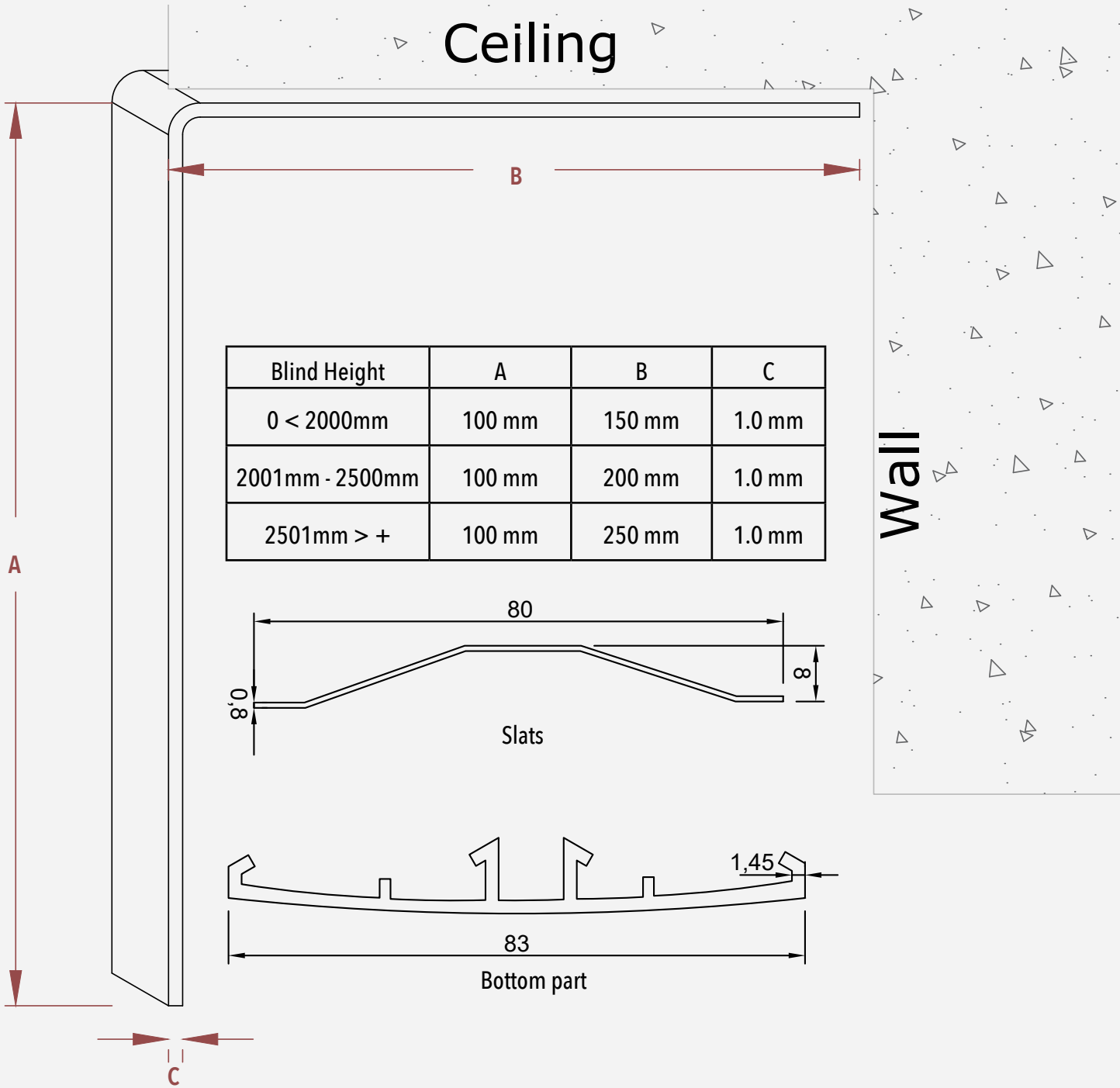

Blind Height	A	B	C
0 < 2000mm	100 mm	150 mm	1.0 mm
2001mm - 2500mm	100 mm	200 mm	1.0 mm
2501mm > +	100 mm	250 mm	1.0 mm

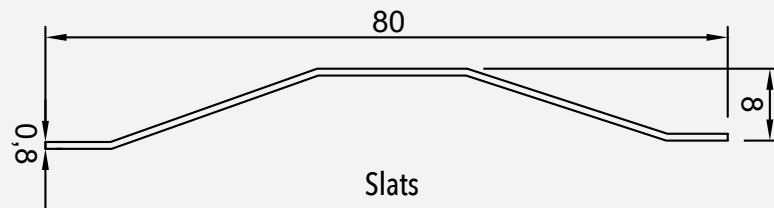

Slats

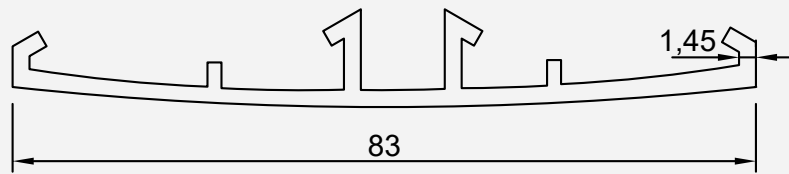

Bottom part

External protection baseboard



PVC-coated 304 stainless steel wire

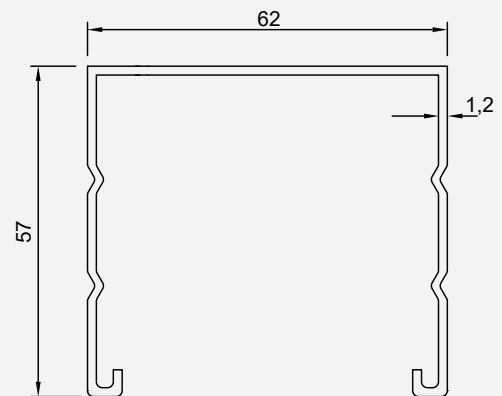

Engine protection box

## EXTERNAL VENETIAN BLINDS SYSTEM

# BORNEO CH

Since the slats move inside a stainless steel channel they are able to resist all harmful environmental influences.

This makes the Borneo CH system long-lasting and sustainable.

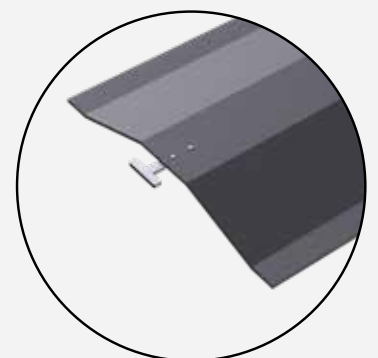
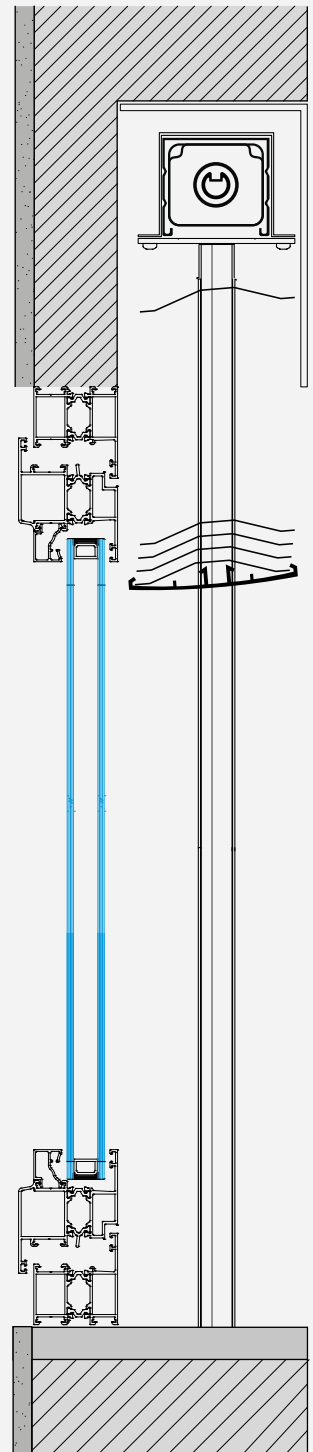

# Ceiling

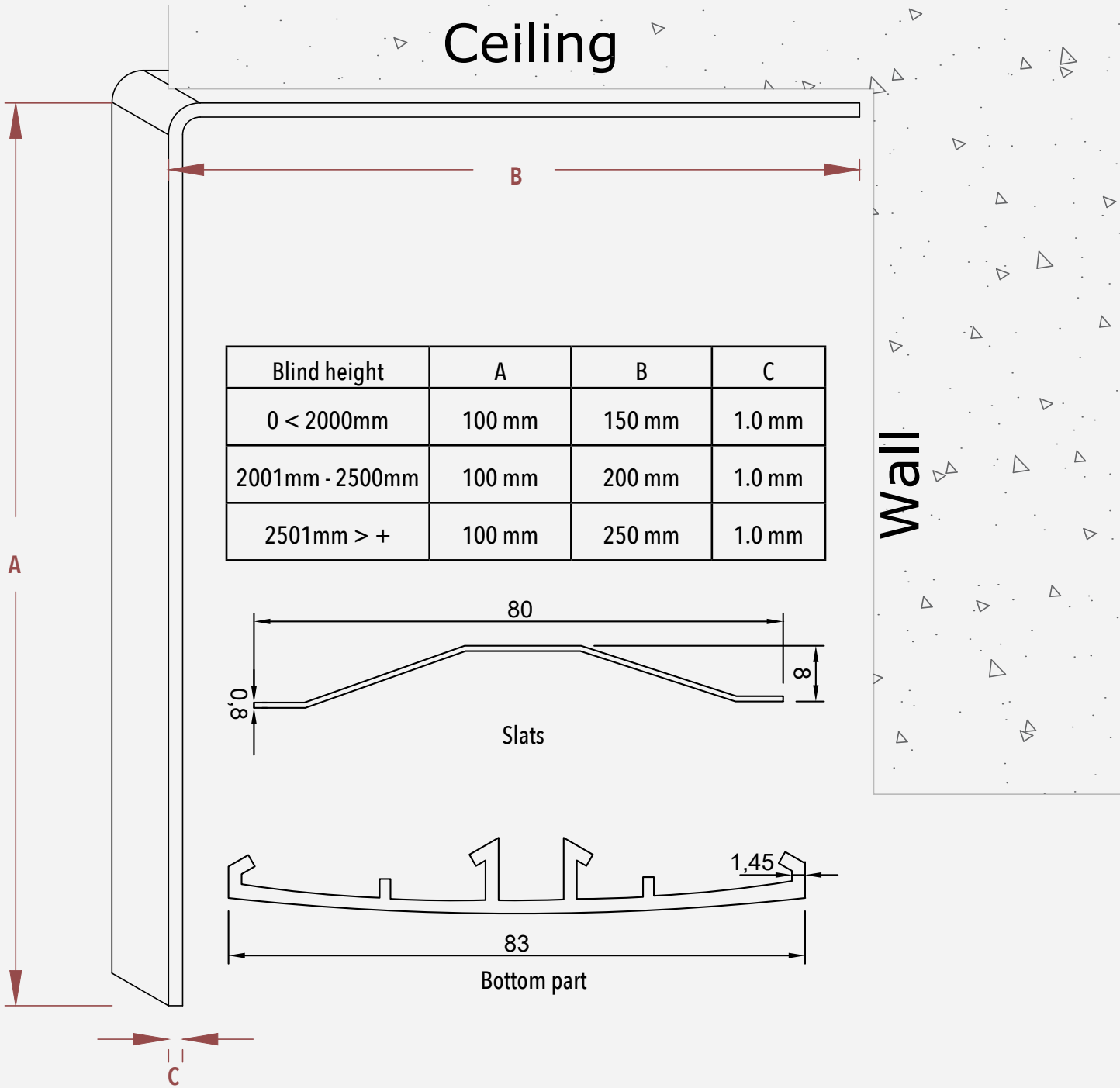

Blind height	A	B	C
0 < 2000mm	100 mm	150 mm	1.0 mm
2001mm - 2500mm	100 mm	200 mm	1.0 mm
2501mm > +	100 mm	250 mm	1.0 mm

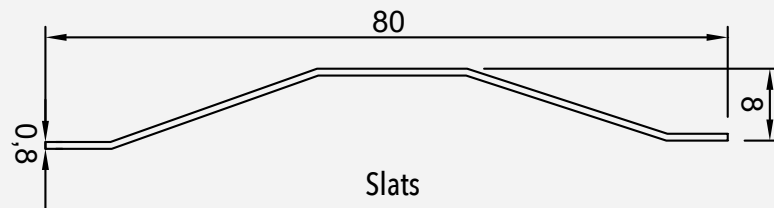

Slats

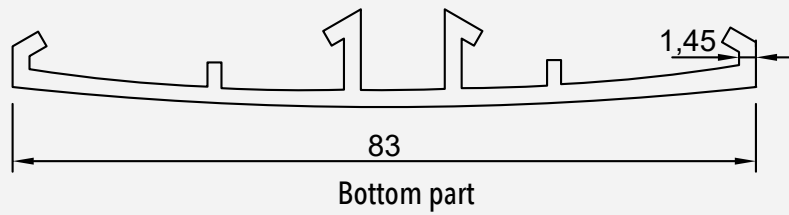

Bottom part

External protection baseboard

Sidebar

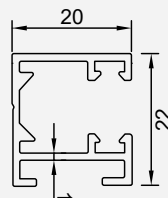

Engine protection box

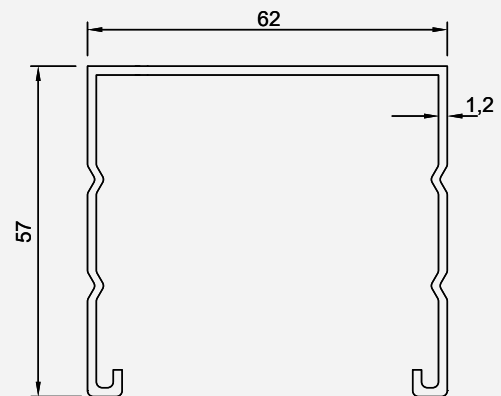

somfy®



DESIGNATION	Nominal torque	Speed with load	Rated Power	Rated Current	Brake Type	Total Length	Weight (with adapter)
J406 RTS TILT	6 Nm	24 / 1 min	95 W	0,40 A	Sliding	306 mm	1,4 kg
J410 RTS TILT	6 Nm	24 / 1 min	110 W	0,50 A	Sliding	321 mm	1,6 kg
J418 RTS TILT	6 Nm	24 / 1 min	155 W	0,70 A	Sliding	341 mm	2,3 kg

DESIGNATION	Noise	Nominal voltage	Maximum Capacity of the LSU	Degree of protection	Temperature working range	
					Normal Use	Exceptional Use
J406 RTS TILT	52 dB	230 V~ / 50 Hz	90 turns	IP 54	-10°C to +40°C	-20°C to +70°C
J410 RTS TILT	55 dB	230 V~ / 50 Hz	90 turns	IP 54	-10°C to +40°C	-20°C to +70°C
J418 RTS TILT	58 dB	230 V~ / 50 Hz	90 turns	IP 54	-10°C to +40°C	-20°C to +70°C

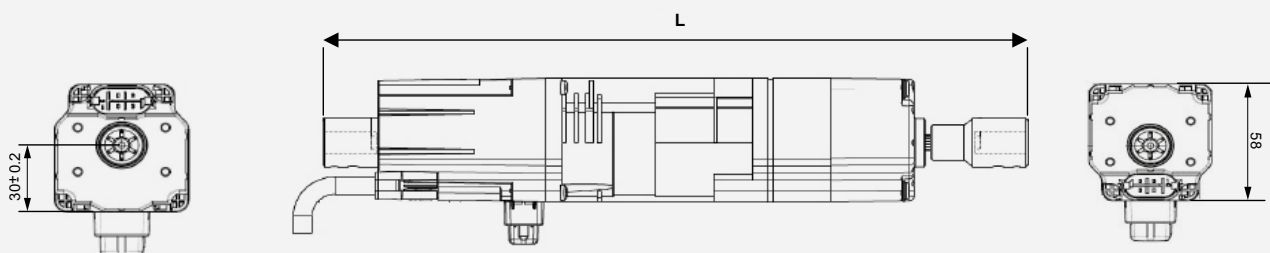



	Pure	Silver
Situo Variation 1 Channel	1811608	1811609
Situo Variation 5 Channels	1811610	1811611
Size	140x45x20 mm	
Protection factor	IP30	
Voltage type	3V	
Radio frequency	433.42 MHZ	
Radio range	20 metres through 2 concrete walls	
Protocol	RTS	
Temperature range-working	0°C to +48°C	

## 24V SOLIRIS RTS SENSOR KIT



### Features

- Power Supply: 24VAC/DC
- Rated Current: 25 mA at 24VDC
- Operating Temperature: -4 to 122 degrees F (-20 to 50 degrees C)
- Dimensions: 6.3(H) x 9.3(L) inches (160 x 236 mm)
- The SOLIRIS sensor RTS is a radio sensor for awnings with an automatic control according to the daylight intensity and protection against wind damage.
- Protection factor IP 34 / class II product
- The wind and sun thresholds can be set directly on the SOLIRIS sensor RTS.
- The SOLIRIS sensor RTS must be used with the OREA RTS and ALTUS RTS motors.

## Rain Sensor ONDEIS



### Features

- Fast, simple and flexible assembly. Wall assembly or installation on standard mast with 50 mm diameter.
- 24 V DC power supply provided directly through the Outside Sensor Box (ref. 9001606).
- Delivered with a 2.30 m cable (2 x 0.75 mm<sup>2</sup>)
- Capacitive measurement of rain and snow.
- Protection of the conductive strips from oxidation by a foil.
- Capacitive sensor which measures the change of electricity field.
- Measurement procedure ensures a fast reaction with simultaneous avoidance of hypersensitivity.
- An integrated, self-regulating heating dries the sensor surface automatically.

# EXTERNAL VENETIAN BLINDS SYSTEM



DESIGNATION	Nominal torque	Speed with load	Rated Power	Rated Current	Brake Type	Total Length	Weight (with adapter)
J406 RTS TILT	6 Nm	26 / 1 min	90 W	0,40 A	Sliding	304 mm	1,6 kg
J410 RTS TILT	2x8 Nm	26 / 1 min	150 W	0,70 A	Sliding	336 mm	2,2 kg
J418 RTS TILT	2x12 Nm	5 / 1 min	90 W	0,40 A	Sliding	311 mm	1,7 kg

DESIGNATION	Noise	Nominal voltage	Maximum Capacity of the LSU	Degree of protection	Temperature working range	
					Normal Use	Exceptional Use
J406 RTS TILT	34 dB	230 V~ / 50 Hz	80 turns	IP 54	-10°C to +60°C	-15°C to +70°C
J410 RTS TILT	40 dB	230 V~ / 50 Hz	80 turns	IP 54	-10°C to +60°C	-15°C to +70°C
J418 RTS TILT	-	230 V~ / 50 Hz	80 turns	IP 54	-10°C to +60°C	-15°C to +70°C

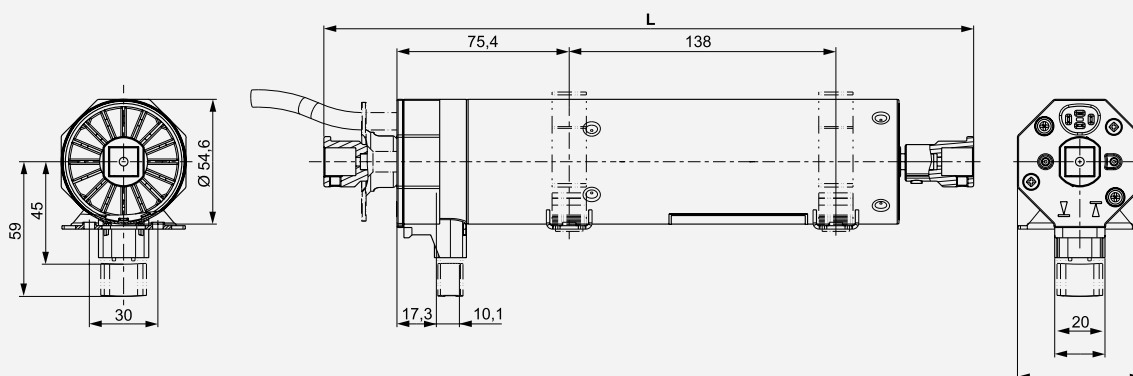



		Black	Silver
GF2006/07	1 Channel	1811608	1811609
GF2010/11	6 Channels	1811610	1811611

- Selection of one or 6 channels
- Stop button to stop the curtain
- Switching the automatic solar function on/off
- Any number of receivers can be assigned to this channel
- Including battery, wall bracket and mounting accessories

### GF0023 | Sun and wind sensor with control cable (230 V)



#### Features

- Individual control. Grouped and centralized control with cut-off relay GU0001
- Programming of a handheld transmitter for operation of wired motors is possible
- Sun sensor can be deactivated
- Adjustable brightness threshold value
- Adjustable wind speed threshold value
- 230 V power supply required
- Connectable external operating key
- Programming of intermediate position
- Sun detection angle 180°

#### Recommendation

- Use with motors with mechanical or electronic end stops

### GF0025 | Sun and wind sensor with radio transmitter (solar-cell powered)



#### Features

- Selection of one channel
- Setting of this channel through a transmitter whose function is copied
- Any number of receivers can be assigned to this channel
- Individual, grouped or centralized control
- Sun sensor can be deactivated
- Adjustable brightness threshold value
- Adjustable wind speed threshold value
- NO 230 V power supply needed: solar-cell powered
- Sun detection angle 180°

#### Recommendation

- Use with GEIGER Venetian blinds motors with GFJ006, GFJ007, GFJ008, GFJ009 and GEIGER tubular motors with radio controls.

Also suitable for application with GFM001, GFU001, GFU002 and GFU004

### GRS001 | Rain sensor (12 V/24 V)



#### Features

- Accurate precipitation measurements (rain and snow)
- Easy mounting
- For 12 and 24 V
- Opening / closing contacts
- Sensor surface can be heated in winter
- Maintenance-free
- UV and weather resistant
- Protection class: IP54
- Adjustable sensitivity
- Optional acoustic signal
- PTC heater against formation ice or condensation
- Dimensions: 80 x 82 x 58 mm
- Mounting kit: GRS002



**BORNEO**  
SYSTEMS